

TECHNICAL SPECIFICATIONS HOSE REEL WITHOUT NITO SPRAY GUN :

| | |
|-------------------------------------|--|
| Hose length in meters | 20 m |
| Working pressure | maximum 20 bar at 25°C (Air) - maximum 10 bar at 70°C (Water) |
| Inlet thread size | 1/2" Male |
| Outlet thread size | 1/2" Male for hose + quick release coupler Female for NITO SPRAY GUN |
| Weight | 21,8 Kg |
| Raw material sides and roll | AISI 304 |
| Raw material shaft and swivel joint | AISI 303 |
| Raw material main spring | Carbon steel |
| Can be used to transfer | Air-Water |

B



AUTOMATIC HOSE REEL
cod. 00803000058

NITO SPRAY GUN :
Working temperature : maximum 40°C
Working pressure : maximum 6 Bar

QICK RELEASE COUPLER 1/2" :
Working temperature : maximum 80°C
Working pressure : maximum 10 Bar

C

D

E

F

FOOD QUALITY HOSE LENGTH 20m - ø13x20
cod. 00403000117

QICK RELEASE COUPLER 1/2"

NITO SPRAY GUN
cod. 00502000010

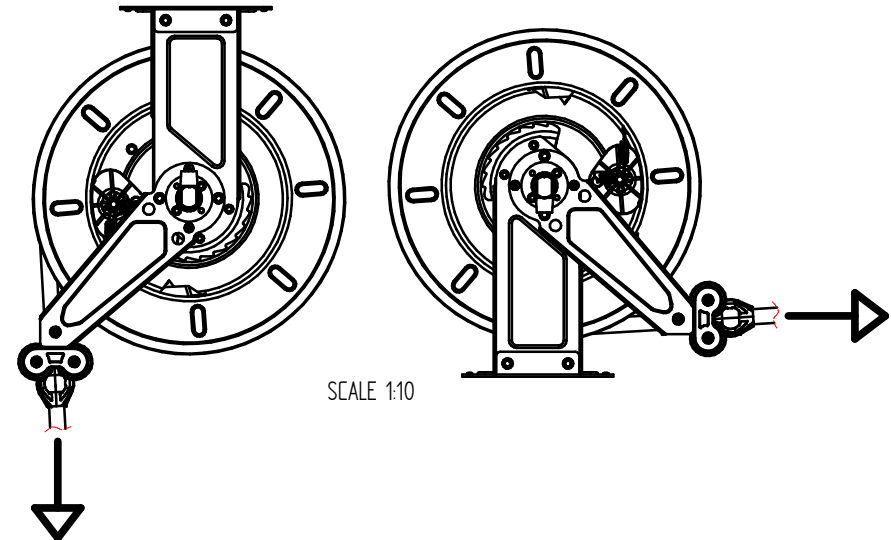

SCALE 1:10

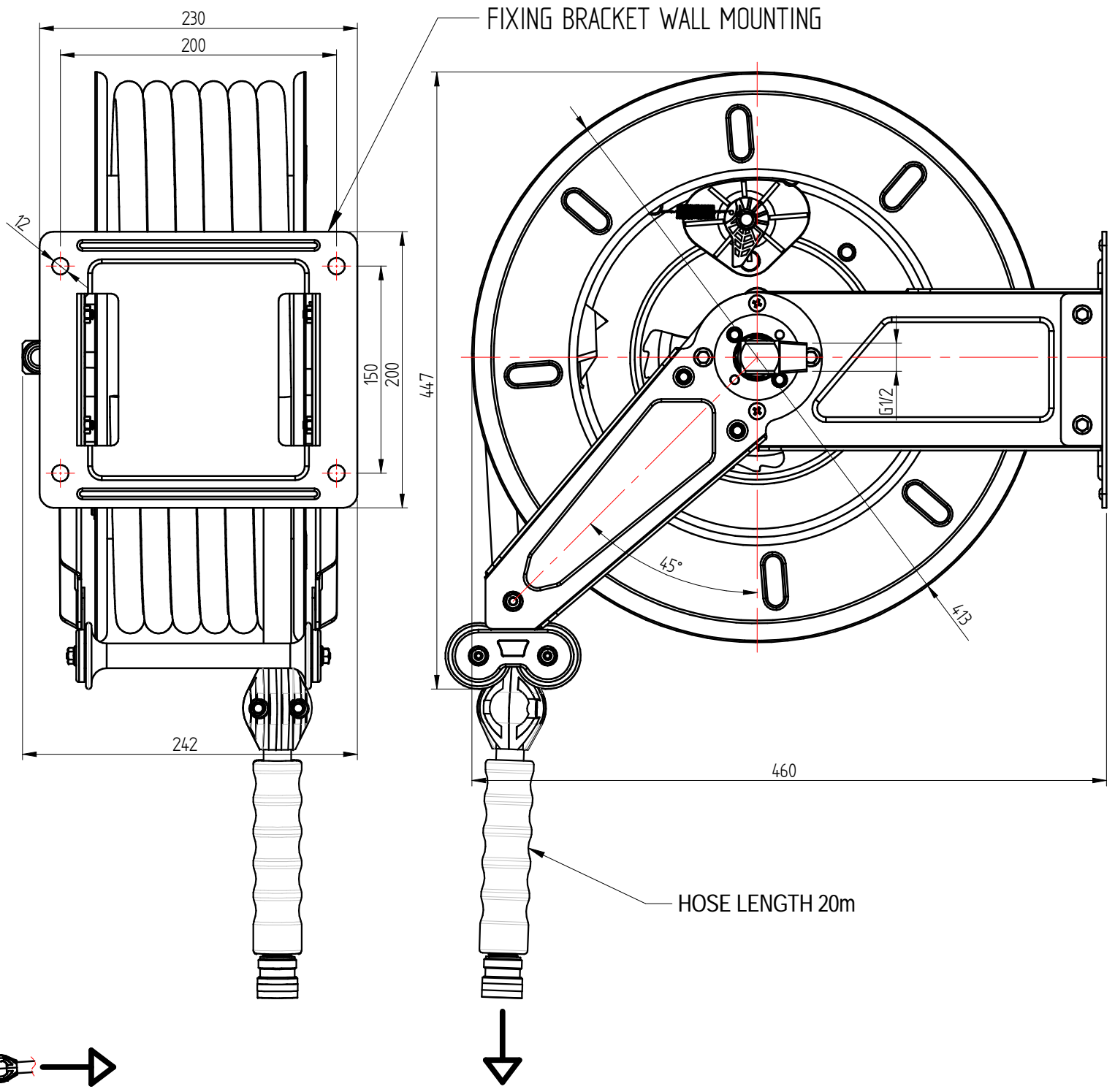

FIXING BRACKET WALL MOUNTING

HOSE LENGTH 20m

| | |
|---|---------------------|
| Shares without tolerance according to standard UNI-EN-22768-1-m | |
| SIZE A3 | European Projection |
| DATE 05-11-2018 | SCALE 14 |
| DRAWN PICCOLO M. | |
| VALIDATE PICCOLO M. | |

DESCRIPTION
STAINLESS STEEL WALL MOUNTED HOSE REEL L=20m
WITH FOOD QUALITY HOSE AND NITO SPRAY GUN

CODE
SR000000033A
WEIGHT
22,1 Kg



VIA DELL'ARTIGIANO 8/F-8-G , 31050 MONASTIER di TREVISO (TV) tel: 0422 842157 - fax: 0422 708978

DONE WITH DESIGN CAD - PROHIBITED THE CHANGES MANUAL

FLOW RATE : 8 L/min