

TECHNICAL SPECIFICATIONS HOSE REEL WITHOUT NITO SPRAY GUN :

Hose length in meters	15 m
Working pressure	maximum 20 bar at 25°C (Air) - maximum 10 bar at 70°C (Water)
Inlet thread size	1/2" Male
Outlet thread size	1/2" Male for hose + quick release coupler Female for NITO SPRAY GUN
Weight	16,4 Kg
Raw material sides and roll	AISI 304
Raw material shaft and swivel joint	AISI 303
Raw material main spring	Carbon steel
Can be used to transfer	Air-Water

AUTOMATIC HOSE REEL  
cod. 00803000057

NITO SPRAY GUN :  
Working temperature : maximum 40°C  
Working pressure : maximum 6 Bar

QICK RELEASE COUPLER 1/2" :  
Working temperature : maximum 80°C  
Working pressure : maximum 10 Bar

FOOD QUALITY HOSE LENGTH 15m - ø13x20  
cod. 00403000116

QICK RELEASE COUPLER 1/2"

NITO SPRAY GUN  
cod. 00502000010

SCALE 1:10

FIXING BRACKET WALL MOUNTING

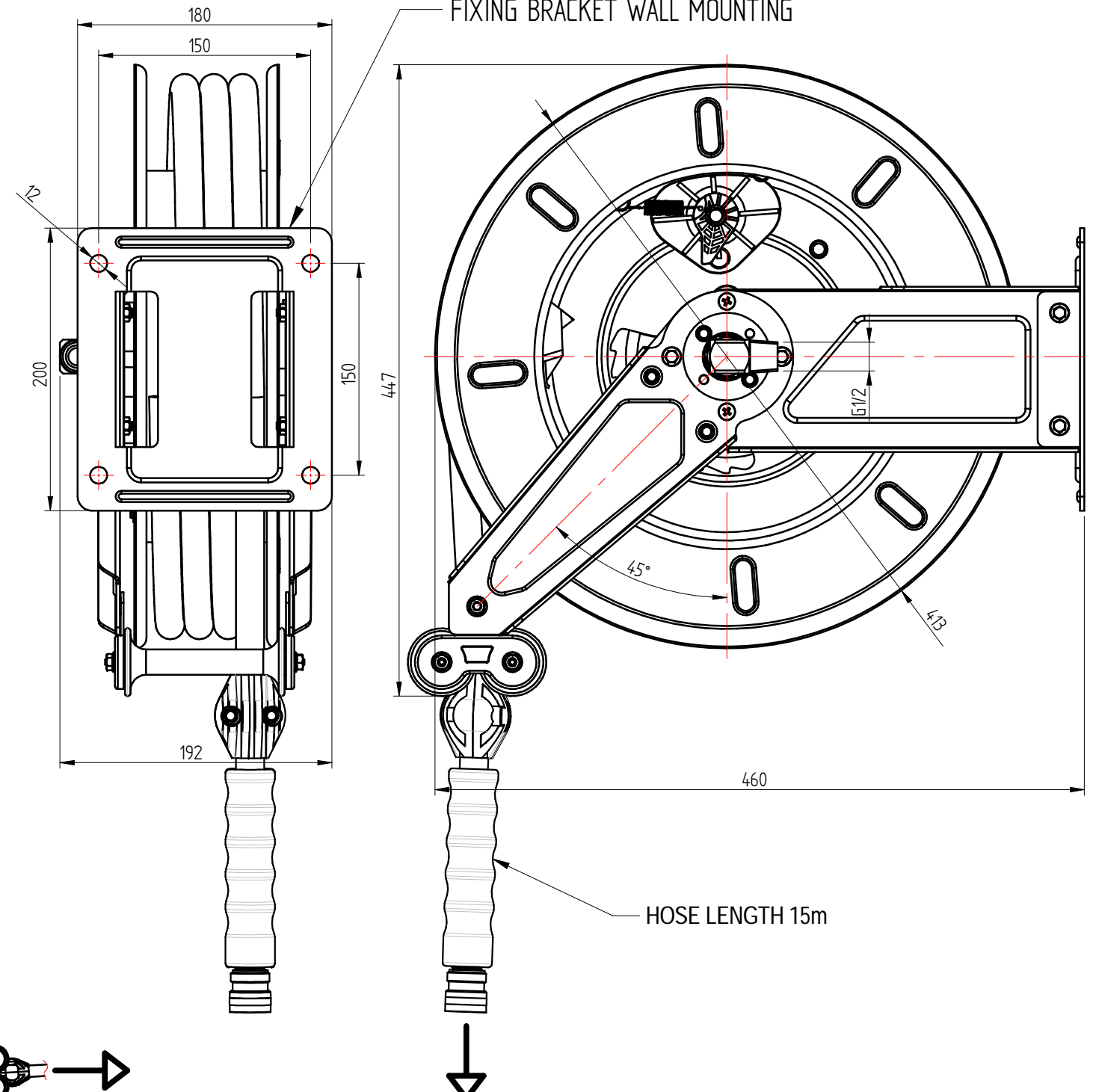

Shares without tolerance according to standard UNI-EN-22768-1-m		DESCRIPTION	CODE
SIZE	A3	STAINLESS STEEL WALL MOUNTED HOSE REEL L=15m WITH FOOD QUALITY HOSE AND NITO SPRAY GUN	SR000000032A
DATE	05-11-2018	SCALE	14
DRAWN	PICCOLO M.	 <p>DESIGN AND TECHNOLOGICAL RESEARCH FOR WATER</p> <p>VIA DELL'ARTIGIANO 8/F-8-G , 31050 MONASTIER di TREVISO (TV) tel: 0422 842157 - fax: 0422 708978</p>	
VALIDATE	PICCOLO M.		
FLOW RATE : 8 L/min			
DONE WITH DESIGN CAD - PROHIBITED THE CHANGES MANUAL			