

TECHNICAL SPECIFICATIONS HOSE REEL WITHOUT NITO SPRAY GUN :

Hose length in meters	10 m
Working pressure	maximum 20 bar at 25°C (Air) - maximum 10 bar at 70°C (Water)
Inlet thread size	1/2" Male
Outlet thread size	1/2" Male for hose + quick release coupler Female for NITO SPRAY GUN
Weight	15,2 Kg
Raw material sides and roll	AISI 304
Raw material shaft and swivel joint	AISI 303
Raw material main spring	Carbon steel
Can be used to transfer	Air-Water

AUTOMATIC HOSE REEL
cod. 00803000057

NITO SPRAY GUN :
Working temperature : maximum 40°C
Working pressure : maximum 6 Bar

QICK RELEASE COUPLER 1/2" :
Working temperature : maximum 80°C
Working pressure : maximum 10 Bar

FOOD QUALITY HOSE LENGTH 10m - $\phi 13 \times 20$
cod. 00403000115

QICK RELEASE COUPLER 1/2"

NITO SRAY GUN
cod. 00502000010

SCALE 1:10

FIXING BRACKET WALL MOUNTING

HOSE LENGTH 10m

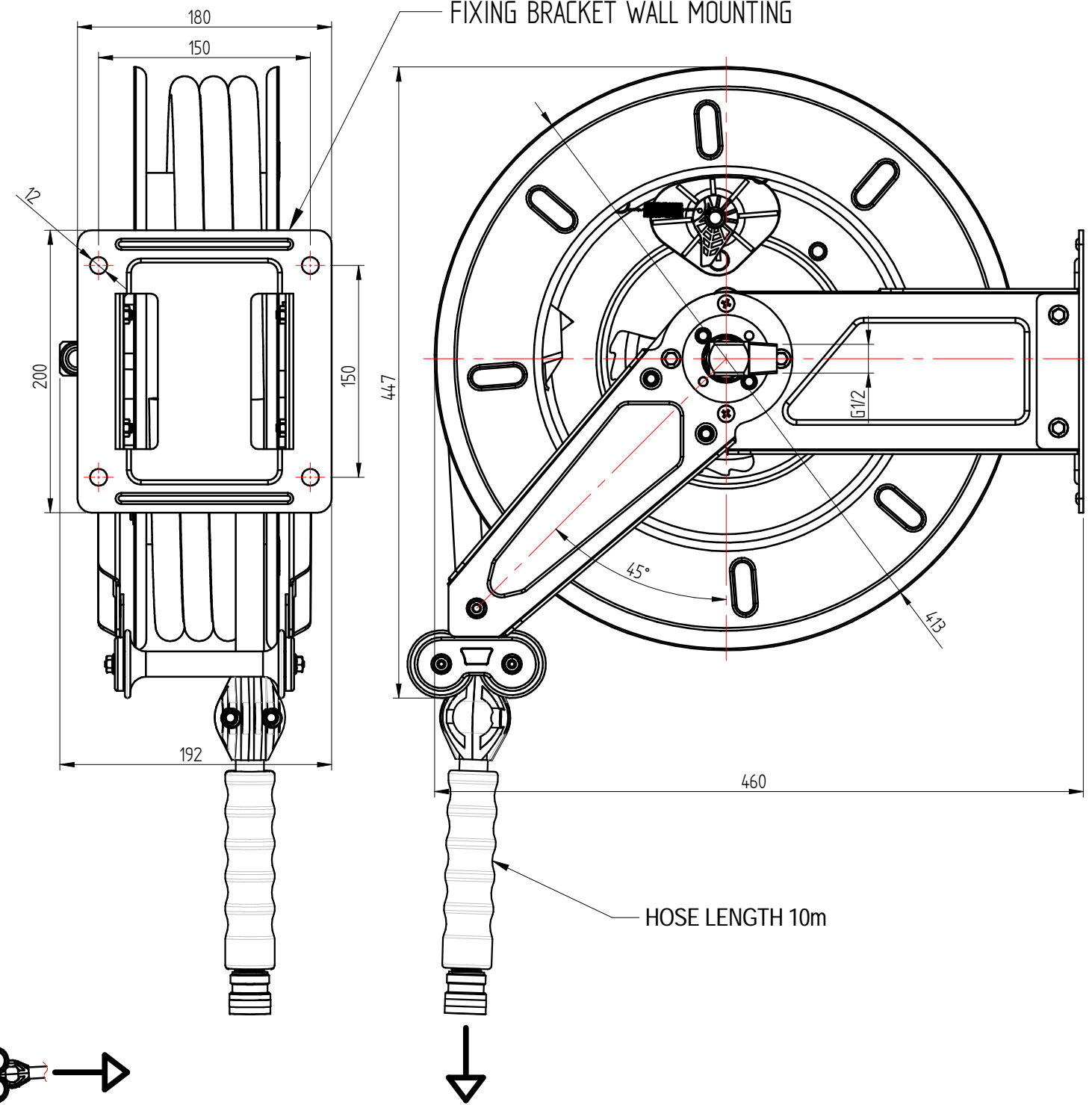

Shares without tolerance according to standard UNI-EN-22768-1-m	
SIZE A3	European Projection
DATE 05-11-2018	SCALE 14
DRAWN PICCOLO M.	
VALIDATE PICCOLO M.	

DESCRIPTION
STAINLESS STEEL WALL MOUNTED HOSE REEL L=10m
WITH FOOD QUALITY HOSE AND NITO SPRAY GUN

FLOW RATE : 8 L/min
CODE
SR000000031A
WEIGHT
15,5 Kg



VIA DELL'ARTIGIANO 8/F-8-G , 31050 MONASTIER di TREVISO (TV) tel: 0422 842157 - fax: 0422 708978

DONE WITH DESIGN CAD - PROHIBITED THE CHANGES MANUAL