

TECHNICAL SPECIFICATIONS HOSE REEL WITHOUT SHOWER :

Admitted diameters	1/4" - 3/8" - 1/2"
Hose length in meters	8 m
Working pressure	maximum 20 bar
Working temperature	maximum 80°C
Inlet thread size	1/2" M
Outlet thread size	1/2" F
Weight	15,6 Kg
Raw material sides and roll	Carbon steel
Raw material shaft and swivel joint	Carbon steel
Raw material main spring	Carbon steel
Can be used to transfer	Air-Water

SHOWER :
 Working temperature : maximum 80°C
 Working pressure : maximum 6 Bar

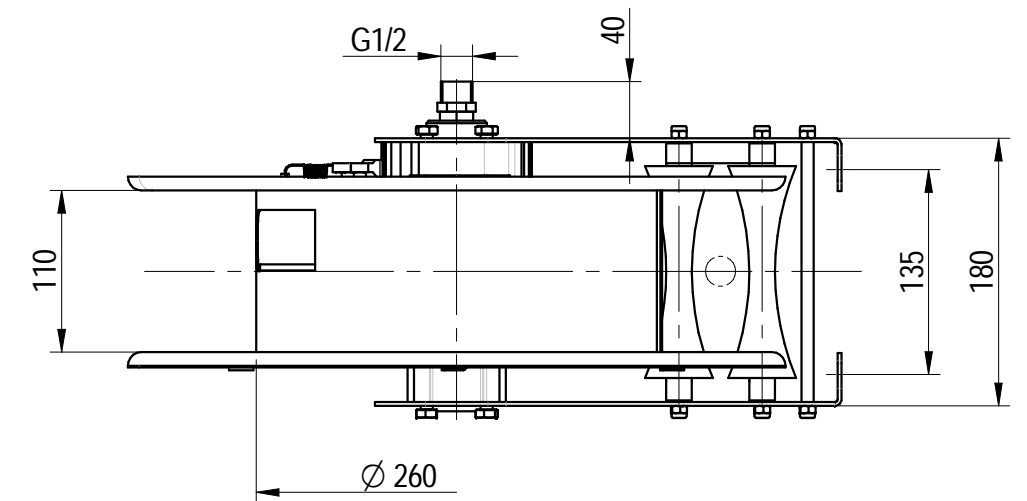
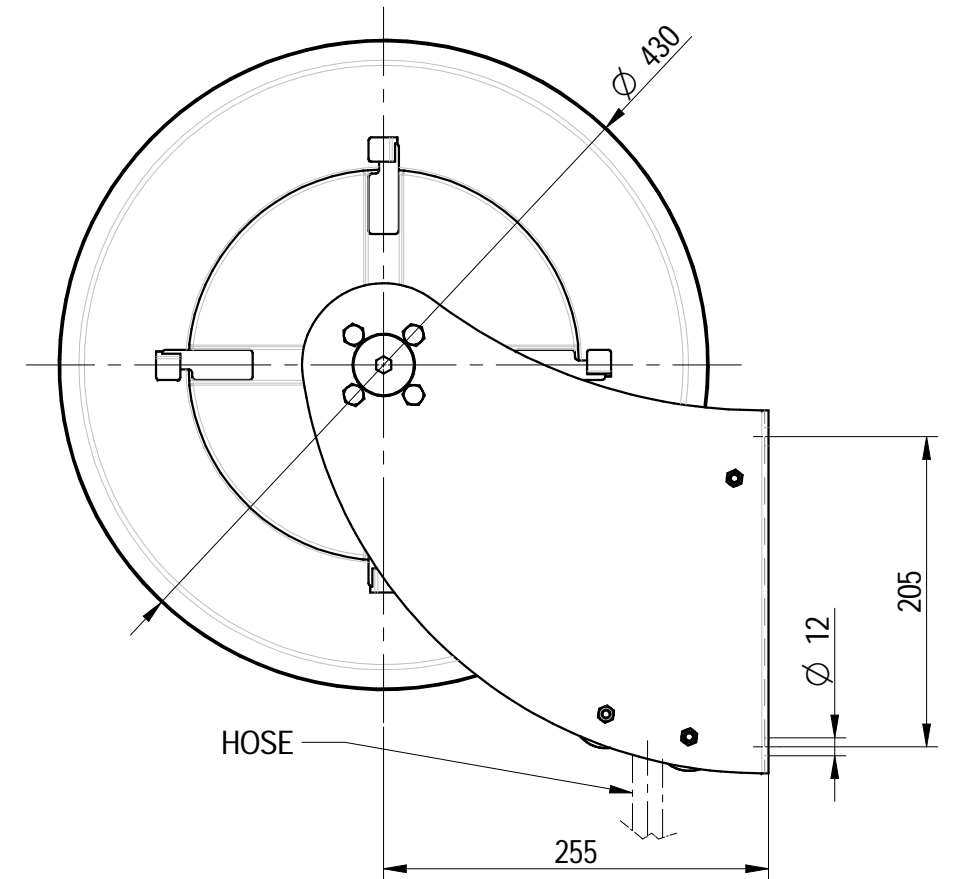

FLOW RATE : 11 L/min at 3,5 BAR

Shares without tolerance according to standard UNI-EN-22768-1-m		DESCRIPTION	CODE
SIZE	 European Projection	POWDER COATED STEEL OPEN HOSE REEL WALL MOUNTED L=8m WITH SHOWER	SR000000012A
A3			WEIGHT
DATE	SCALE	 DESIGN AND TECHNOLOGICAL RESEARCH FOR WATER	VIA DELL'ARTIGIANO 8/F-8-G , 31050 MONASTIER di TREVISO (TV) tel: 0422 842157 - fax: 0422 708978
05-11-2018	15		
DRAWN	PICCOLO M.		
VALIDATE	PICCOLO M.	DONE WITH DESIGN CAD - PROHIBITED THE CHANGES MANUAL	