

TECHNICAL SPECIFICATIONS HOSE REEL WITHOUT NITO SPRAY GUN :

Admitted diameters	1/4" - 3/8" - 1/2"
Hose lenght in meters	10 m
Working pressure	maximum 20 bar
Working temperature	maximum 80°C
Inlet thread size	1/2" M
Outlet thread size	1/2" F
Weight	17,2 Kg
Raw material sides and roll	AISI 304
Raw material shaft and swivel joint	AISI 303
Raw material main spring	Carbon steel
Can be used to transfer	Air-Water-Chemical

NITO SPRAY GUN :
 Working temperature : maximum 40°C
 Working pressure : maximum 6 Bar

QICK RELEASE COUPLER 1/2" :
 Working temperature : maximum 80°C
 Working pressure : maximum 10 Bar

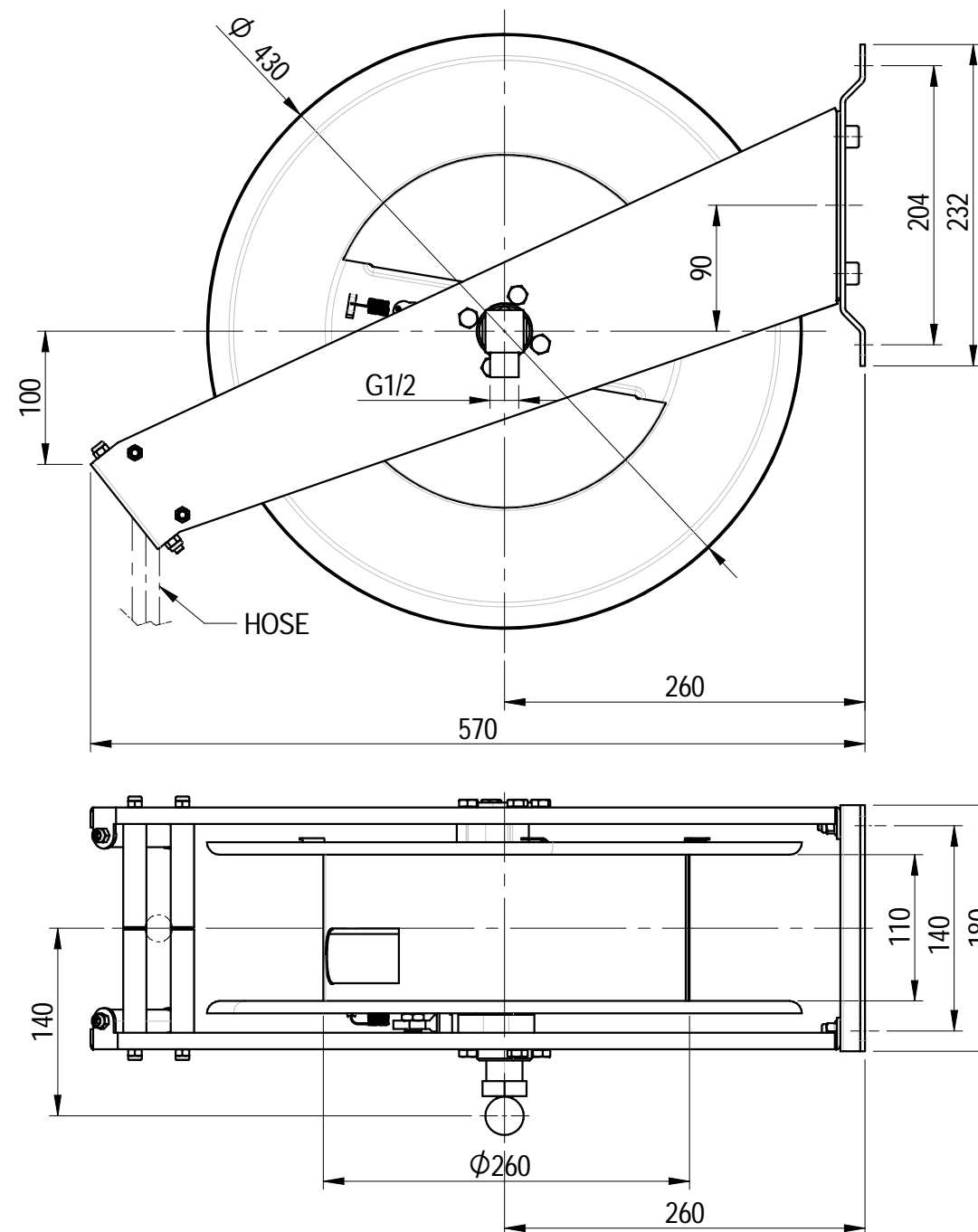
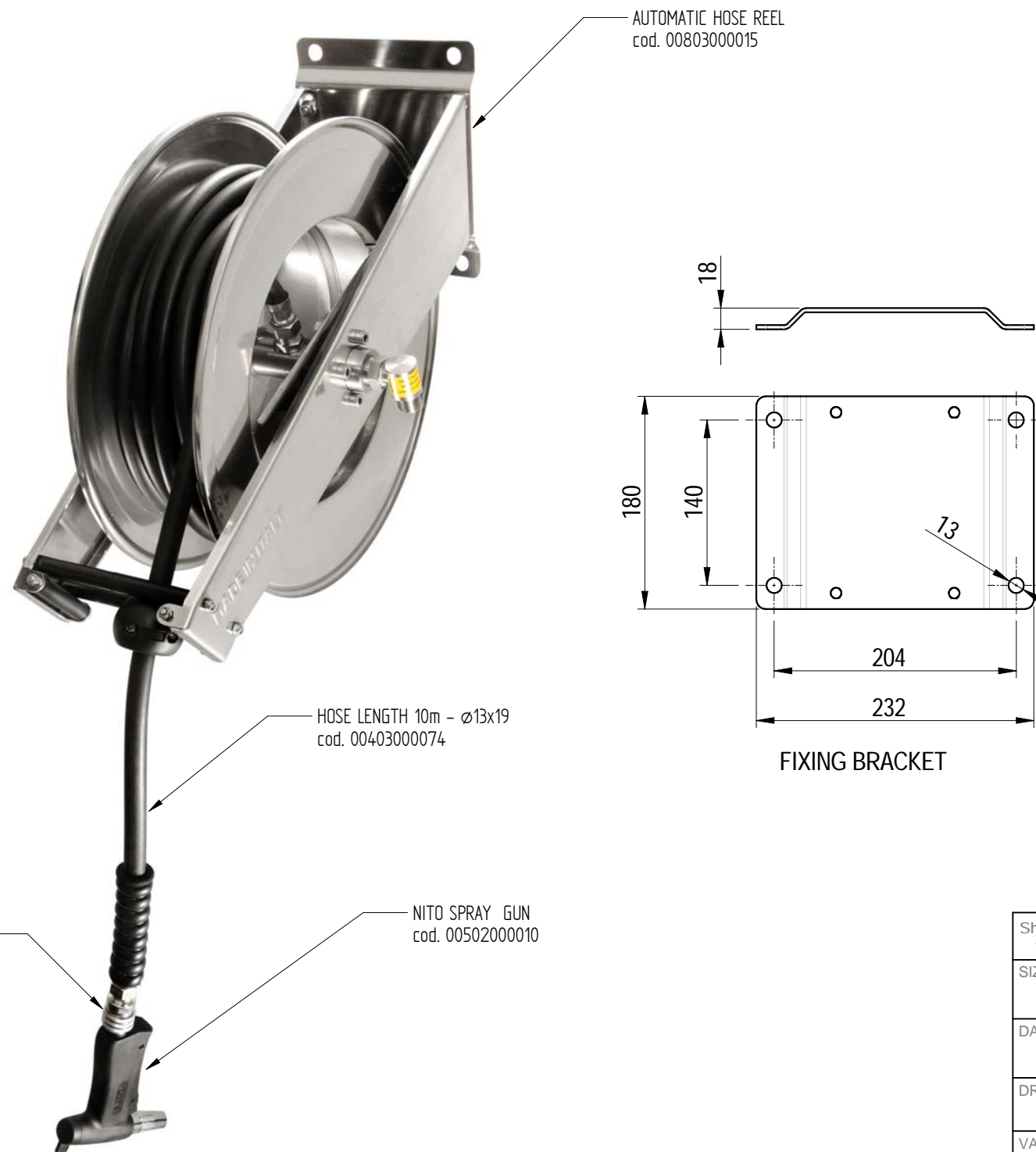

Shares without tolerance according to standard UNI-EN-22768-1-m		DESCRIPTION	CODE
SIZE	A3	STAINLESS STEEL WALL MOUNTED HOSE REEL L=10m + NITO SPRAY GUN	SR000000002A
DATE	31-10-2018		WEIGHT
DRAWN	PICCOLO M.		17,5 Kg
VALIDATE	PICCOLO M.		
		 DESIGN AND TECHNOLOGICAL RESEARCH FOR WATER VIA DELL'ARTIGIANO 8/F-8-G , 31050 MONASTIER di TREVISO (TV) tel: 0422 842157 - fax: 0422 708978	
DONE WITH DESIGN CAD - PROHIBITED THE CHANGES MANUAL			